

LINEARISATION TECHNIQUES: THE KEY TO THE USE OF MORE EFFICIENT MODULATION SCHEMES AND RF POWER AMPLIFIERS

J.A. Ojo¹ and O. Adegbenro²

¹Department of Electronic & Electrical Engineering, Ladoke Akintola University of Technology, P.M.B. 4000, Ogbomoso (210001), Nigeria.

²Department of Electrical & Electronics Engineering, University of Lagos, Nigeria.

ABSTRACT:

This paper gives a brief description of linear modulation schemes and how they are more efficient for data communication. Different classes of RF power amplifiers with respect to their efficiencies are also discussed, as well as different linearisation techniques presently in use and those at the Research and Developmental stage. This paper illustrates with examples how more efficient modulation schemes and more efficient classes of RF power amplifiers can be adopted for use in data communications, if the inherent problem of spectral spreading, which results from non-linear output of RF power amplifiers at the front end of devices can be effectively handled.

INTRODUCTION

Radio frequency (RF) spectrum is a natural 'scarce' resource and in recent times has become more expensive, therefore has to be used wisely. New innovations and recently developed services have created the need for increased data rate capability, resulting to the need for larger bandwidth for wireless operators. In addition, there is a need to ensure that all services can co-exist without causing harmful interference to one another. To avoid interference, sufficient guard bands have to be introduced between operators' allocated frequencies and this in itself results in inefficient use of the RF spectrum. To optimise the use of the frequency spectrum in meeting the explosive demands for high-speed data rates, there is a need to develop a more spectrally efficient system (modulation scheme and front-end devices). Thus, there is the need for a change from the old, less efficient modulation schemes to high data rate multi-level modulation schemes, which provide inherently greater data rates for a given bandwidth. In mobile radio systems, interest has been focused on Gaussian Phase Shift Keying (GFSK), Quadrature Phase Shift Keying (QPSK) and Quadrature Amplitude Modulation (QAM) with specific interest in the 16-QAM and $\pi/4$ - QPSK. However, the use of linear modulation techniques has not been fully embraced due to the effect of the front-end devices that may cause distortions, especially in the RF mixers and power amplifiers.

The mostly used forms of Radio Frequency (RF) linear amplifier are the class-A, class-B and class-AB, whereas these classes of amplifiers are not the most efficient form of amplifiers available. The more efficient RF power

amplifiers, however, have non-linear response. These can result in unacceptable generation of signals outside the allocated frequency channel or band (i.e. spectral spreading), which is referred to as Spectral Re-growth and can lead to Co-channel Interference (if the guard band between channels is small, the spectral re-growth will interfere with the signal quality in the adjacent channels). As a result, specific spectral constraints (performance specifications) have to be placed on RF users to avoid interference. The use of linear modulation schemes in mobile communication, therefore, requires the use of highly linear RF amplifiers and some form of linearisation technique.

Linearisation is a systematic procedure for reducing amplifier's distortion, it allows an amplifier to produce more output power and operate at a higher level of efficiency. The most common forms of linearisation are the feedforward, the feedback and the predistortion techniques, while other forms are still in the research stage.

This paper is presented as follows; section 2 outlines some of the research work earlier done in this area. In section 3, a brief description of linear modulation schemes and how they are more efficient for data communication. Different classes of RF power amplifiers with respect to their efficiencies are treated in section 4. The fifth discusses the Cartesian loop transmitter as a linearisation technique, while section 6 explains the results for the simulations carried out for a 16-QAM signal used as an example of a linear modulation format, a class-C amplifier model as an example of a non-linear RF power amplifier and the Cartesian loop technique as the linearisation technique.

BACKGROUND

The increasing demand for high-data-rate wireless applications has led the development and use of spectrally efficient modulation schemes. It was reported in [1] that DMC Stratex Networks developed an STM-1/OC3 128QAM point-to-point radio that uses half the bandwidth of any existing radios at 18 GHz and above. Also, a more spectrally efficient dc-free modulation scheme called Hierarchical QAM (HQAM), a modulation scheme that uses QAM modulation in two stages was proposed in [2]. In [3], a review of amplifier configurations, classes of operation, device characterisation and example applications was presented, where only class-A amplifier is classified as having a linear output but with low efficiency of 50%, while the more efficient ones produce non-linear outputs. To reduce the distortion introduced by non-linear amplifiers, different linearisation methods have been developed.

The most commonly used forms of linearisation are the Feedforward, the Feedback and the Predistortion techniques while others are in the Research and Development (R&D) stages [4,5,6]. The Feedback technique (Cartesian loop transmitter) has been widely applied in wireless and microwave applications. Other methods still in the Research and Development (R&D) stages generally referred to as Synthesis techniques, are Linear Amplification Using Non-linear Components (LINC) and the Combined Analogue-Locked Loop Universal Modulator (CALLUM), [7,8,9]. Mann et al [10] described the effect of power efficiency of the RF transmitter stage in mobile handsets on the battery capacity as well as talk-time between battery recharge cycles.

LINEAR MODULATION SCHEMES

Linear modulation schemes can be defined as those in which information is transmitted in both the amplitude and the phase of the carrier signal. The envelope of the RF signal produced by these modulation schemes varies with time; therefore, the envelope must be preserved in order to be able to recover the full information content of the original signal after processing or transmission. One of such modulation schemes, 16-QAM, is discussed in this paper.

Complex envelope representation of modulated signals.

All bandpass waveforms, whether they arise from a modulated signal or noise may be represented in a convenient form given by:

$$V(t) = \text{Re}\{g(t)e^{j\omega_c t}\} \tag{1}$$

where $\omega_c = 2\pi f_c$, f_c is the baseband carrier frequency

$\text{Re}\{*\}$ indicates the real part of $V(t)$, while $g(t)$ is the complex envelope of $V(t)$

$$\text{i.e. } V(t) = R(t) \cos[\omega_c t + \theta(t)] \tag{2}$$

$\theta(t)$ represents any variation in the phase.

Also in Cartesian form, a modulated signal can be represented as

$$V(t) = x(t) \cos \omega_c t - y(t) \sin \omega_c t \tag{3}$$

given that $g(t) = x(t) + jy(t) = R(t)e^{j\theta(t)}$

$$\text{where } x(t) = \text{Re}\{g(t)\} = R(t) \cos \theta(t)$$

$$y(t) = \text{Im}\{g(t)\} = R(t) \sin \theta(t)$$

$$R(t) \Rightarrow |g(t)| = \sqrt{x^2(t) + y^2(t)}$$

$$\theta(t) \Rightarrow \angle g(t) = \tan^{-1} \left(\frac{y(t)}{x(t)} \right)$$

Quadrature Amplitude Modulation

Quadrature Amplitude Modulation (QAM) can be described as a combination of AM and PM modulation schemes. It provides a good combination of high data rates (twice the rate of standard PAM), efficient use of available bandwidth, low bit error rates as well as easy demodulation of RF (earlier modulated) signal. It can be interpreted as a single carrier that is both amplitude and phase modulated or two carriers of identical frequency, but one is exactly 90° out of phase with respect to the other.

QAM comprises of two components: the in-phase (I) component and the quadrature (Q) component, which is at 90° phase shift with respect to the I-component. It can be represented mathematically as:

$$S(t) = I(t) + Q(t) \tag{4}$$

$$S(t) = x(t) \cos \omega_c t - y(t) \sin \omega_c t$$

By trigonometry;

$$S(t) = A(t) \cos[\omega_c t + \Phi(t)] \tag{5}$$

This can be interpreted as a single carrier with fixed frequency but variable amplitude and phase.

In QAM, each carrier is modulated to one of several permitted (digital) levels. With n distinct levels for each carrier, a total of $n \times n = (n^2)$ unique digital states can be represented. By using two ($n/2 = 2$) bit digital-to-analogue converters and quadrature modulator a 16-symbol (4 x 4) QAM can be generated as shown in Figure 1

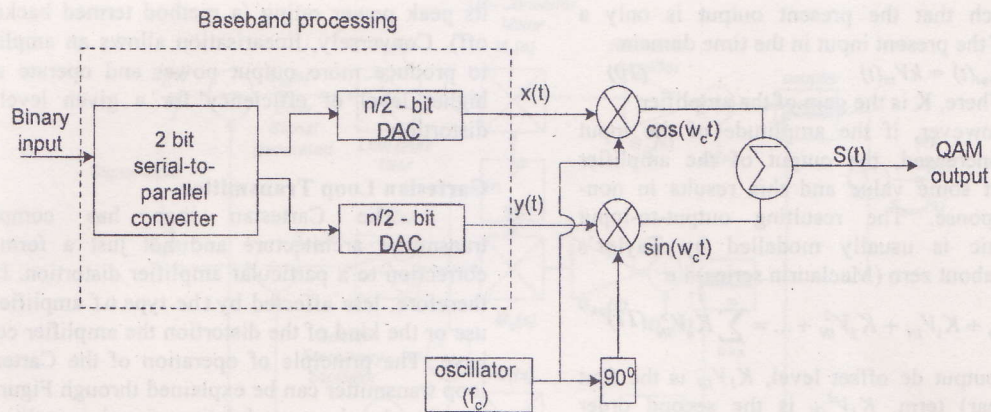

Figure. 1 Generating QAM modulated signals.

Spectral Efficiency of Multi-level Signalling.

Spectral efficiency of a digital signal is given by the number of bits per second of data that can be supported by each Hertz of bandwidth.

$$\eta = \frac{R}{B} \text{ (bits/sec)/ Hz} \tag{6}$$

Where R is the data rate and B is the required bandwidth.

Any reduction in the bandwidth required to process a digital signal will result to increase in the efficiency of the signalling method. For example, if the digital signal is converted from binary signal to multi-level signal using an *l*-bit digital to-analogue converter to produce a $L = 2^l$ multi-level signal

$$\text{Then, } \eta = l \text{ (bits/sec)/Hz} \tag{7}$$

Therefore, spectral efficiency for multi-level signalling is directly represented as the number of bits used in converting the signal to multi-level (DAC).

For QAM and MPSK signals ($M = 2^l$), spectral efficiency will be $\eta = \frac{R}{B} = \frac{l}{2} \text{ (bits/sec)/ Hz}$. For

example, for 16-QAM signal the bandwidth efficiency is $\eta = 2 \text{ bit/sec per Hertz of bandwidth}$.

RF POWER AMPLIFIERS

Radio frequency (RF) Power Amplifiers (PA) are broadly categorised into two; linear power amplifiers, which preserves the original waveshape (amplitude-time-frequency) attribute of the input signal and non-linear power amplifiers, which do not preserve the original attributes of the input signal. Linear PA have a frequency domain transfer function so that each point along the time domain curve that defines the input signal perfectly maps into the output signal in direct proportion with constant time delay. Therefore, the plot of output against the input signal is a straight line. Linear

amplifiers are further categorised into classes depending on their circuit configurations, operational topologies, linearity and efficiency. These are classes A, B and AB. Class A amplifiers used as a power amplifier typically operates at 10% – 30% efficiency in order to minimise distortion. All small signal amplifiers are class A amplifiers, although it could also be used for large signals. Class B power amplifier efficiency is considerably higher than that of class A (up to 66%) while it still provides useful level of linearity. The distortion introduced by class AB amplifier is generally worse or greater than that of a class A amplifier, but less than that of a class B amplifier. As a result, the efficiency of a class AB amplifier is less than that of class B and greater than that of class A amplifier, usually between 40% and 60%. Non-linear amplifiers are those in which no attempt is made to preserve the original waveshape of the input signal at the output. There is a larger number of non-linear amplifier classes, some of which are designated as class C, D, E, F, G, H and S [11].

Distortion in Power Amplifiers.

Distortion is the phenomenon that describes the deviation of the output of a communication system from being a processed replica (amplified or filtered) of the input or original signal.

The expected output of a distortionless communication system can be said to be a delayed version of the input i.e.

$$y(t) = Ax(t - T_d) \tag{9}$$

where, $x(t)$ is the input, $y(t)$ is the output of the channel, and T_d is the delay

Non-linear distortion in amplifiers

In the analysis of non-linear distortion, amplifiers that have no “memory effect” are used (i.e. no capacitive and inductive effects in their

circuit) such that the present output is only a function of the present input in the time domain.

i.e. $V_{out}(t) = kV_{in}(t)$ (10)

Where, K is the gain of the amplifier.

However, if the amplitude of the input signal is increased, the output of the amplifier saturates at some value and this results in non-linear response. The resulting output-to-input characteristic is usually modelled by Taylor's expansion about zero (Maclaurin series) i.e

$$V_{OUT} = K_0 + K_1V_{IN} + K_2V_{IN}^2 + \dots = \sum_{n=0}^{\infty} K_n V_{IN}^n \quad (11)$$

K_0 is the output dc offset level, K_1V_{IN} is the first order (linear) term, $K_2V_{IN}^2$ is the second order (square-law) term, and $K_3V_{IN}^3$ is the third order term, e.t.c.

The transfer characteristic of an amplifier with a second order (non-linear) factor is given as;

$$V_{OUT}(t) = K_1V_{IN}(t) + K_2V_{IN}^2(t)$$

Consider the case of a single sinusoidal tone input

i.e. $V_{IN}(t) = A_0 \sin w_0t$

$$V_{OUT}(t) = K_1A_0 \sin w_0t + \frac{K_2A_0^2}{2}(1 - \cos 2w_0t) \quad (12)$$

In frequency domain, this indicates that a second signal component now exists at twice the original frequency ($2w_0$), this is referred to as the Second Harmonic Distortion, a form of non-linear distortion. In addition, a dc term also results from the second-order term.

The transfer characteristics of an amplifier with a third order term is given as;

$$V_{OUT}(t) = K_1A_0 \sin w_0t + \frac{K_3}{2}(A_0 \sin w_0t - A_0^3 \sin 3w_0t) \quad (13)$$

There is an addition of a term at three times the original input signal frequency, this is the third harmonic signal and it is generally referred to as the Third Harmonic Distortion.

LINEARISATION TECHNIQUES

Linearisation can be described as a systematic procedure for reducing distortion in amplifiers or mixers. Preceding the use of linearisation techniques, linearity of power amplifiers was achieved at the expense of power efficiency by reducing the signal level to the amplifier such that its output power is well below

its peak power rating (a method termed backing-off). Conversely, linearisation allows an amplifier to produce more output power and operate at a higher level of efficiency for a given level of distortion.

Cartesian Loop Transmitter.

The Cartesian loop has complete transmitter architecture and not just a form of correction to a particular amplifier distortion. It is, therefore, less affected by the type of amplifier in use or the kind of the distortion the amplifier could have. The principle of operation of the Cartesian loop transmitter can be explained through Figure 2. The baseband or modulating signal is split into quadrature components prior feeding it to the transmitter forming two signal paths. The quadrature components are then fed into differential amplifiers, which form the subtraction that generates error signals from the combination of the feedback signals and the new sample signals. The error signal generated is passed through a low pass filter in each quadrature path.

The outputs of the filters are up-converted (mixed) to RF using a quadrature RF oscillator (comprising of two carriers of the same frequency but one is 90° out of phase with the other. The resulting RF signals from the two paths are then added to produce a complex RF output signal, which is amplified by the non-linear power amplifier.

The output of the PA is sampled by a directional coupler and attenuated to a suitable level to feed the downconversion mixers. The downconversion mixers are supplied with exactly the same local oscillator signals as with the upconversion mixers, this ensures that the upconversion and downconversion processes are coherent. The downconverted output signals forms the feedback path to the differential amplifiers to generate the next error signal thereby closing the loops. There is need for a phase shift between the upconversion and the downconversion process to ensure that the two processes are correctly synchronised, this is due to the delay through the loop especially in the RF amplifier. The phase shift is provided in the local oscillator path feeding either the upconversion mixers or the downconversion mixers. Details of the analysis of the transmitter is presented in [12].

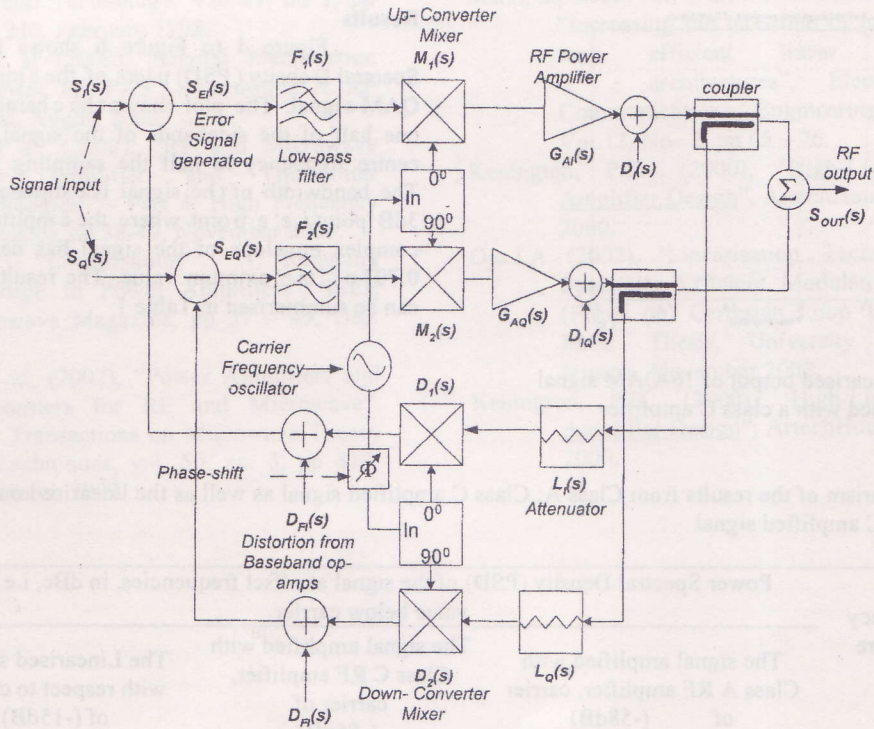

Figure 2: The Cartesian Loop Transmitter

SIMULATIONS.

This section discusses the results of simulation for a 16-QAM signal of 60kbps (data) rate. Figure 3 shows the complex envelope of the simulated signal. Figure 4 and Figure 5 shows the Power Spectral Density (PSD) plot of the same signal amplified by a class A and class C RF power amplifiers, respectively, using the polynomial fit model for the amplifiers [13]. Figure 6 shows the linearised output (using the Cartesian Loop Transmitter techniques) of the class-C amplified signal.

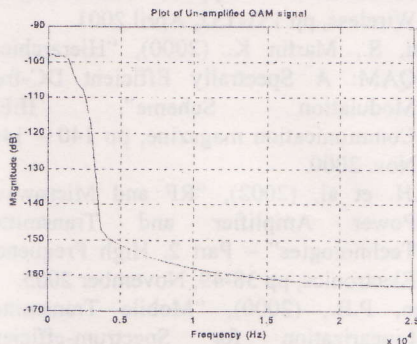

Figure 3: The Plot of Un-amplified 16-QAM signal.

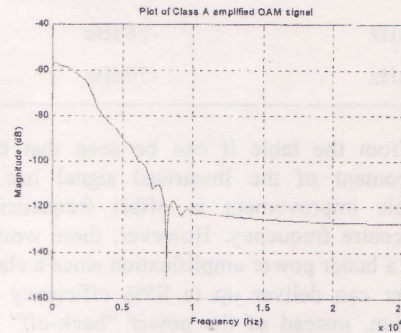

Figure 4: The plot of 16-QAM signal amplified with a class A amplifier

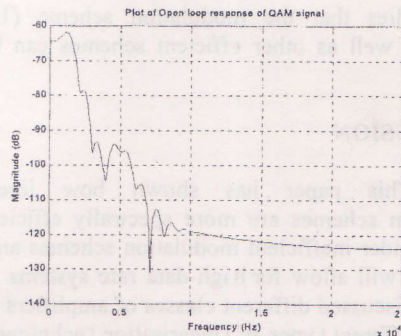

Figure 5: Unlinearised output of 16-QAM signal amplified with a class C amplifier

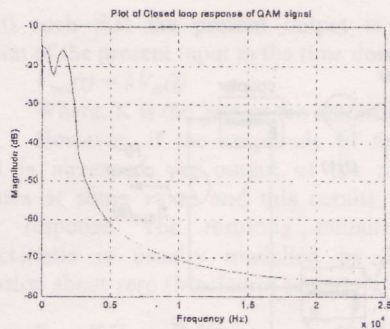

Figure 6: Linearised output of 16-QAM signal amplified with a class C amplifier

Results

Figure 4 to Figure 6 shows the Power Spectral Density (PSD) plots of the simulated 16-QAM signal. The plot shows the characteristic of one half of the sidebands of the signal, from the centre frequency to half the sampling frequency. The bandwidth of the signal is estimated at the -3dB point i.e. a point where the amplitude of the complex envelope of the signal has decreased to 0.707 of its maximum value. The results obtained can be summarised in Table 1

Table 1: Comparison of the results from Class A; Class C amplified signal as well as the linearised output of the Class C amplified signal

Offset frequency from the centre frequency (kHz)	Power Spectral Density (PSD) of the signal at offset frequencies, in dBc, i.e. dB value below carrier.		
	The signal amplified with Class A RF amplifier, carrier of (-58dB)	The signal amplified with Class C RF amplifier, carrier of (-65dB)	The Linearised signal, with respect to carrier of (-15dB)
10kHz	-64dBc	-55dBc	-56dBc
15kHz	-66dBc	-57dBc	-60dBc
20kHz	-68dBc	-59dBc	-61dBc
25kHz	-70dBc	-61dBc	-63dBc

From the table it can be seen that the spectral content of the linearised signal has a considerable improvement at offset frequencies from the centre frequency. However, there would have been a better power amplification since a class C amplifier can deliver up to 95% efficiency in amplification, instead of the power “back-off” in class A amplifiers with only 30% maximum efficiency. In addition, despite the more efficient amplification, it can be seen that the complex envelope of the modulated signal was preserved. This implies that the modulation scheme (16-QAM) as well as other efficient schemes can be adopted.

CONCLUSION

This paper has shown how linear modulation schemes are more spectrally efficient than the older inefficient modulation schemes and, therefore, will allow for high-data rate systems. It has also discussed different classes of amplifiers as well as different types of linearisation techniques. Also discussed are the effects of using more efficient modulation schemes as well as more efficient power amplifiers. Through linearisation of

RF amplifiers outputs, higher power efficiency can be achieved while the originality of the signal transmitted is still preserved.

REFERENCES

Gibson, P., (2001), “Maximising the Potential of Radio Spectrum with High-Order Modulation”. Applied Microwave & Wireless, pp 131-132, April 2001.

Mirabbasi, S., Martin K. (2000), “Hierarchical QAM: A Spectrally Efficient DC-free Modulation Scheme”. IEEE Communication magazine, pp 140 – 146. Nov. 2000.

Raab, F.H. et al, (2002), “RF and Microwave Power Amplifier and Transmitter Technologies” – Part 2. High Frequency Electronics, pp 38-49, November 2003.

Kenington, P.B., (2000), “Mobile Transmitter Linearization for Spectrum-efficient Modulation Formats”, The Radio Science Bulletin, no 293, pp 16-20, June 2000.

Faulkner, M. (1998), “Amplifier Linearization Using RF Feedback and Feedforward Technique”, IEEE Transactions on

- Vehicular Technology. Vol 47, no 1, pp 208 – 210, February 1998.
- Zavosh, F. et al (2000), "Digital Predistortion Linearises RF PAS", Microwave & RF Journal, August 2000.
- Raab, F.H. et al, (2002), "RF and Microwave Power Amplifier and Transmitter Technologies" – Part 4. High Frequency Electronics, pp 38-49, November 2003.
- Katz, A. (2001), "Linearization Reducing Distortion in Power Amplifiers", IEEE Microwave Magazine, pp 37 – 49, Dec. 2001.
- Raab, F.H. et al, (2002), "Power Amplifiers and Transmitters for RF and Microwave". IEEE Transactions on Microwave Theory and Techniques, vol. 50, no. 3, pp 814-826, March 2002.
- Mann, S., Beach M., Warr P., McGeehan J. (2001), "Increasing the talk-time of mobile radio with efficient linear transmitter architectures", Electronics & Communication Engineering Journal, Vol.13, No- 2, pp 65 – 76.
- Kenington, P.B., (2000), 'High-Linearity RF Amplifier Design', ArtechHouse, London, 2000.
- Ojo J.A., (2002), 'Linearisation Techniques For Spectrally Efficient Modulation Formats (Focus on) Cartesian Loop Transmitter', M.Sc. Thesis, University of Lagos, Nigeria, November 2002.
- Kenington, P.B., (2000), 'High-Linearity RF Amplifier Design', ArtechHouse, London, 2000.